



E&A (Europe & Africa) WATER SKI FEDERATION RACING RULES (2012)

The 2012 E&A Racing Rules have been ratified by the E&A Racing Council.

Edited by Vera Van den Bossche, Thea Klarenbeek & Jules Leysen E&A Racing Council Members and thanks to all officials that helped with the updates. **ANY NEW OR REWORDED RULES ARE INDICATED IN RED.**

Electronic version of these rules are available at IWWF.com, E&A (Racing) & skirace.net

This booklet covers E&A Racing rules only – For World Championship refer to IWWF for National races refer to your individual country.

Updated January 2012

CONTENTS PAGE ORDER

INDEX 2

Technical Rules

<u>RULE 1</u>	General	3
<u>RULE 2</u>	Competitions Format	26,27,28
<u>RULE 3</u>	Entry requirements	3
<u>RULE 4</u>	Judges - Race Officials	4
<u>RULE 5</u>	Boat Specifications	6
<u>RULE 6</u>	Competitors Equipment	16
<u>RULE 7</u>	Flags	18
<u>RULE 8</u>	Departure & Circuit	19
<u>RULE 9</u>	Conduct of the race	22
<u>RULE 10</u>	Timing	24
<u>RULE 11</u>	Protests	25
<u>RULE 12</u>	Penalties	25

<u>EUROPE CUP</u> : Rules	26
Licences	28
Competition Format	26

<u>EUROPEAN CHAMPIONSHIPS</u> : General	28
Licences	28
Competition Format	28
Team Trophy	29

INDEX

ALCOHOL	Consumption of	4.17,9.16,9.19
ANCHOR	Type/Line	5.22,5.23
BATTERY	Stowage	5.19
BILGE PUMP		5.29
BLOOD GROUPS		3.03
BOATS	Length	5.01
	Structural	5.21
	Distances	8.03, 9.06, 9.12
	Decibels	5.17
	Substitution	8.11
BRIEFING	Pre Race	4.14
BUOYANCY		5.25
CALCULATORS		4.12,4.13
CHAMPIONSHIPS	Frequency	Page 26,28
	Format	Page 28
COMPASSES		5.26
COMPETITIONS	Europe Cup	Page 26
	Championship	Page 28
COMPETITORS	Behaviour	8.09, 9.15, 9.18
CONTROL CABLES		5.08,5.09
CREWS	Definitions	6.01
	Age	6.02
DISPLAY BOARD	With Boat Number	7.04
DISQUALIFICATIONS		12.02
DRIVER	Conduct	8.08,9.07, 9.11,9.12,
DROP OFF AREA		4.14 9.14
DRUGS	Consumption of	9.17
ENGINE	Condition	5.15
	Displacement	5.02
	Electric. harness	5.16
	Eligibility	5.20
	Exhaust Systems	5.17
	Mountings	5.14
	Wells	5.30
FINISH OF RACE		8.14 10.03
FIREFIGHTING EQUIP	Competitors	5.24
	Safety boats	4.16
FIXED PENALTIES		12.02
FLAG POLE HOLDER		5.31
FLAGS	Orange	6.09, 9.01, 9.02
	Specifications	7.01, 7.02, 7.03
FLARES		5.28
FOOTRESTS		5.13
FOOTWEAR		6.07 § 6
FUEL	Lines	5.11
	Tanks	5.10
GIVING WAY	During race	9.11
GRID POSITIONS	Start Lines	8.13
HANDHOLDS	Observers	5.13
HELMETS	Specifications	6.08
	Wearing of	9.13
INSURANCE	Third party	3.04
JACK PLUG		5.12
JUDGES	Chief	4.02, 4.03, 4.06 4.07,4.12,
	Assistant	4.02, 4.04

JURY	Appointment of	4.02, 4.03, 4.05
LICENCES	International	3.01, 3.05
	Home country	3.05
	Suspension	12.03
LIFE JACKETS	Skiers	6.06
	Crew	6.07
MEDICAL	Presence	4.15
NUMBERS	Dimensions	5.03
	On trailers	5.27
OBSERVERS	Conduct	9.01,9.05
OVERTAKING		8.05,8.07, 808,
		9.04, 9.06, 9.10
PADDLES		5.32
PENALTIES		Rule 12
POINTS	Calculation	10.05
POINTS SCORERS		Page 26,27,,28
PROPELLERS	Security	5.18
PROTESTS		Rule 11
RACE COURSES		8.01, 8.02,8.03
RACE DISTANCES		8.01, 8.03
RACE ORGANISER		4.08,4.09, 8.10
RESCUE SERVICE		4.09,8.10
RULES	Amendments	1.05
	Exceptions	1.03
	General	1.01 1.02
	Interpretation	1.04
SAFETY OFFICER		4.09
SCRUTINEER		4.10
SEATS		5.13
SHARP EDGES	Fittings	5.06
SKIER	Contact	9.02
	Fastening	9.08 9.09
	Position	9.03 10.04
SKIS		6.03
STARTER		4.11
STARTS	Types of	8.02
	Procedure	8.03 8.04
STEERING	Gear etc	5.08
SUMMARY	Judgment	12.04
TEAMS	Divisions	Pages 26,27,28
	Notification	3.01, 3.02
THROTTLE	Control	5.12
TIMEKEEPERS		4.12,4.13
TIMING		10.01 10.02
TOWING CLEAT		5.04
TOW LINE	Skiers	6.04, 6.05
TOW ROPE	Boats	5.05
TURNS	Marking of	8.05
	Conduct	8.05, 9.10
	Control of	4.03,8.06
VIDEO CAMERAS		4.03
WINDSHIELD		5.07

RULE 1: GENERAL

- 1.01** These rules set forth are the E&A Technical Rules for Water Ski Racing. Whenever the masculine is used, the same shall be construed as meaning the feminine where the context so requires.
- 1.02** These rules are concerned with:
a) Circuit Races (more than 2 laps)
b) Distance Races (point to point)
- 1.03** Exception to the rules - complementary rules. Where compliance with the rules is impossible and where complementary rules in connection with the circuit are needed, complementary articles will be set forth by the organisers, in agreement with:
1. for Europe Cup and International Open races,
2. for European Championships,
these complementary rules have to be sent to the E&A Racing Council, together with the Technical Dossier.
- 1.04** Interpretation of the rules
Questions of interpretation of the rules shall be referred to the E&A Racing Council. Any interpretation made by E&A Racing Council as a whole shall be considered final and the Chief Judge shall make a detailed homologation and report to the E&A Racing Council.
- 1.05** Amendments to the rules
The rules may be amended at any time by the E&A Racing Council. They shall become effective sixty (60) days after they are sent to the Member Federations or immediately on the grounds of safety.

RULE 2: COMPETITION FORMAT

See regulations under Europe Cup and European Championships below (26-29).

RULE 3: ENTRY REQUIREMENTS

- 3.01** Each competitor must have in his possession an international licence issued by his Federation, endorsed by Region Racing Council on behalf of IWWF.
- 3.02** Each Federation shall notify the organisers of the names of their teams participating. The Chief Judge shall be notified of the Team members by the Team Captain prior to the start of each race.
- 3.03** A Team is defined as one skier, pilot and observer. The skier may be towed by a boat with pilot and/or observer of different nationalities. The E&A Racing Council consider that the skier is the member of the team who defines the teams nationality. Each skier, pilot and observer must notify the organisers of their blood groups.
- 3.04** All entrants must be insured for third party insurance and each boat must be insured against third party risks for a minimum of **€ 2.000.000** or the equivalent in local currency. Competitor to competitor insurance although desirable is not compulsory. The current policy of insurance with a valid renewal receipt for the same must be included within the Dossier.
- 3.05** In addition, any driver residing in a country whose Government controls the issue of boat driver licences shall not be permitted to compete in a race unless he has possession of such a licence.

RULE 4: JUDGES - RACE OFFICIALS

- 4.01** At the beginning of the year of competition Judges/Scrutineers/Timekeepers/Calculators will be notified of the seasons calendar of racing and asked to urgently confirm their availability. Appointments will be ratified at the January or March/April E&A Racing Council meeting and officials notified of their appointments.
- 4.02** The E&A Racing Council shall then appoint the Chief Judge, the Assistant to the Chief Judge, 4 Jury members, Chief Scrutineer, Chief Calculator and the Chief Timekeeper.
- 4.03** The control and observation at turn buoys will be carried out by Judges and assisted by National Judges who will submit a report to the Chief Judge at the end of the race. Only Official video cameras shall be admissible in the case of a protest. Judges will not discuss any possible penalties over the radio during the race.
- 4.04** **Assistant Judge:** shall be a qualified International Judge from the host country. He/She will act under the Chief Judges instructions. He/She should involve themselves in checking the Dossiers and assisting with scrutineering prior to racing.
- 4.05** **The Chief Judge** is responsible for briefing his Assistant Judge and Jury members and for verifying the time-keepers, lap recorders, calculators carry out their jobs correctly. The Chief Judge will act as Chairman of the jury. In case of disagreement between the jury the majority shall decide. In case of a tie the Chief Judge shall decide. He/she shall not serve as a Jury member. The Chief Judge's decision shall be final for the event. Any subsequent appeal should be directed to the E&A Racing Council.
- 4.06** **Jury:** The 4 Europe Cup and 4 European Championship International Judges appointed from as many different countries as possible will be briefed by the Chief Judge and report infringements of the rules they have observed to the Chief Judge as soon as possible. They are not empowered to impose penalties themselves directly. They will assist the selected scrutineers with their duties acting as scribes whilst scrutineering is taking place on the day prior to racing.
- 4.07** When there is a judging report, the Team Captains should be interviewed together with the competitors involved. The Judge making the report should also be interviewed. All relevant information should be discussed during consideration of the judging report with the Judge making the report, the Team Captains and the competitors involved all having the opportunity of making comments. After all relevant parties have had an opportunity to be heard the Jury shall makes its decision which will be communicated via the Chief Judge to the Team Captain prior to the posting of the results. When all adjudication has concluded the final results will be posted and the Jury decision will be final for the event and not subject to an appeal.
- 4.08** **Race Organiser:** shall be appointed and/or approved by the appropriate authority for the level of the competition and will be responsible for the pre-race organisation. He/She will act under the direction of the Chief Judge on the day or days of the Races and must not be a competitor at that event unless a replacement is provided.
- 4.09** **Safety Officer:** normally a member of the organising Federation with expert knowledge of local water conditions, responsible for deployment of safety boats and advising the Race Organiser and the Chief Judge of dangerous conditions. He may also be required to advise the Race Organiser and Chief Judge on the likely safety of competing boats under local water conditions before the Chief Judge allows the first boat to start in a race.

It is the Safety Officer's responsibility to brief rescue boat drivers and to check that all competing and officials boats are safely accounted for at the conclusion of racing. The Safety Officer, with the consent of the Chief Judge, shall take whatever action is necessary whenever he observes a condition to be unsafe. He shall remain in personal or radio contact with the Chief Judge.

- 4.10 Chief Scrutineer:** appointed by E&A Racing Council for each event and by reason of his/her special technical knowledge of ski boats. Has overall responsibility for seeing that the 4 selected scrutineers carry out their roles correctly and has the final say, in consultation with the Chief Judge, in any scrutineering problem. Responsible for seeing no boat starts in the race until it and competitors equipment meets all the Technical Rules and the engine(s) fall within the class structure for which entry has been made.
Scrutineers: 4 members of competing nation's who regularly scrutineer in their own country will be selected and will work alongside the 4 jury members in teams of two to scrutineer all boats within the time schedule for the event.
- 4.11 Starter:** normally someone with reasonable experience of water ski racing. Will be appointed and briefed by the Chief Judge in consultation with the Race Organiser.
- 4.12 Chief Calculator and Timekeeper** will be appointed by E&A Racing Council Assistants to come from Organising Federation but are ultimately responsible to the Chief Judge.
- 4.13** Lap scorers and Calculators will be appointed by the Race Organizer of organizing Federation, but are ultimately responsible to the Chief Judge.
- 4.14** The organisers must hold a pre-race briefing supervised by the Chief Judge and the Safety Officer, during which fullest possible details must be given concerning navigation, details on overtaking, course and safety of the competition, including the drop off area at the conclusion of the race. Team captains must be present.
- 4.15** A qualified Medical Practitioner or trained Paramedic must be present at events and on site during race practice. Their decision on a competitor's fitness is final.
- 4.16** All Judge, rescue and safety boats must carry appropriate fire fighting equipment.
- 4.17** On the day of the competition no alcohol is to be consumed by Judges and Officials until after completion of the competition.
- 4.18** All Judges must be available for scrutineering and official team practice according to the race schedule.
- 4.19** All Judges should act without bias and in a fair and sporting manner and not discuss decisions outside of the Jury room before during or after a race.

RULE 5: SPECIFICATION OF COMPETING BOATS

The Chief Scrutineer will be responsible to the Chief Judge and the scrutineering standards are given herewith:

5.01

- A. Boats used for towing skiers must not exceed 6.5 meters in overall length. The overall length is measured between the two perpendiculars, one at the bow of the boat (A), the other at the point where the bottom intercepts the transom (B). (See diagram #1 and #1BIS). Intersection of keel and transom is key to all other measurements.
- B. An extension shall be for the purpose of mounting an outboard motor (s) or a drive leg(s) to the transom of the boat used for towing skiers. The extension can be attached as a fabricated bracket and bolted to the transom or it can be molded to the transom of the boat. Maximum length of the extensions and power unit (s) combined shall be 1.4 meters. There is a minimum dimension of 150 mm (6") measured from the lowest part of the extension to the intersection of the bottom of the boat to the transom, or the projected line of the transom if it does not continue to the bottom of the hull. No part of the extension shall be in the water while the boat is on plane.
- C. No "COSMETIC" extensions or protrusions are allowed in the 150 mm (6") NO GO ZONE. (See drawing # 2--View to transom) Adjustable trim tabs ARE allowed in this 150 mm (6") NO GO ZONE.
- D. The length of the outward chine shall be limited to 6.60 m in overall length (A to D see Drawing # 1) This allows for some design in the outward angle of the transom, the additional 0.10 m is equal to 3.937 inches.

Drawing # 2 with top views, side view and view to transom are part of this rule. B - C is defined as----Transom to propulsion point (e.g. end of propeller shaft, nozzle of jet unit, 1.4 m

EXCEPTIONS TO RULE 5.01 AND DATES OF EXPIRATION.....

The Force F-1 and the Bernico F-2, both with side pod extensions and approved by scrutineers in World Championships 2003--2005--2007--2009, shall be allowed to participate in the 2011 World Championships. The expiration date of this exemption shall be December 31, 2011. After that date all boats towing skiers shall comply with the revised rule 5.01 dated December 20, 2009.

N.B. The Bernico Models which were allowed to compete in 2009 but were issued with a letter of non compliance, dated July 17th, 2009, & issued to boats 3/91, 13, 16, 222, 32, 21, 72, are not allowed to participate in 2011 unless modified and approved by the IWWF Racing Council as complying with the new rule.

NEWLY DESIGN BOATS FOR TOWING SKIERS.....

Boats that have NOT been entered into an IWWF World Racing Championship prior to 2009 shall have their design and measurements approved by the IWWF Racing Council before construction and entering a World Championship.

F2 Boat length AB 5.48 m to 6.5 m

[PENALTY 12.01 – Disqualification](#)

“E&A comply with the rule 5.01 as voted by the IWWF subject to an E&A amendment that all existing boats F1 and F2 manufactured in 2009 and before are allowed to compete in our E&A Region as per our rules.

Agreed by E&A Racing council. For the future – we agree to change the rule, but existing boats should be allowed to continue for their natural life.

For all new boats details and serial number label must be provided to the Racing Council as per the CE requirements.”

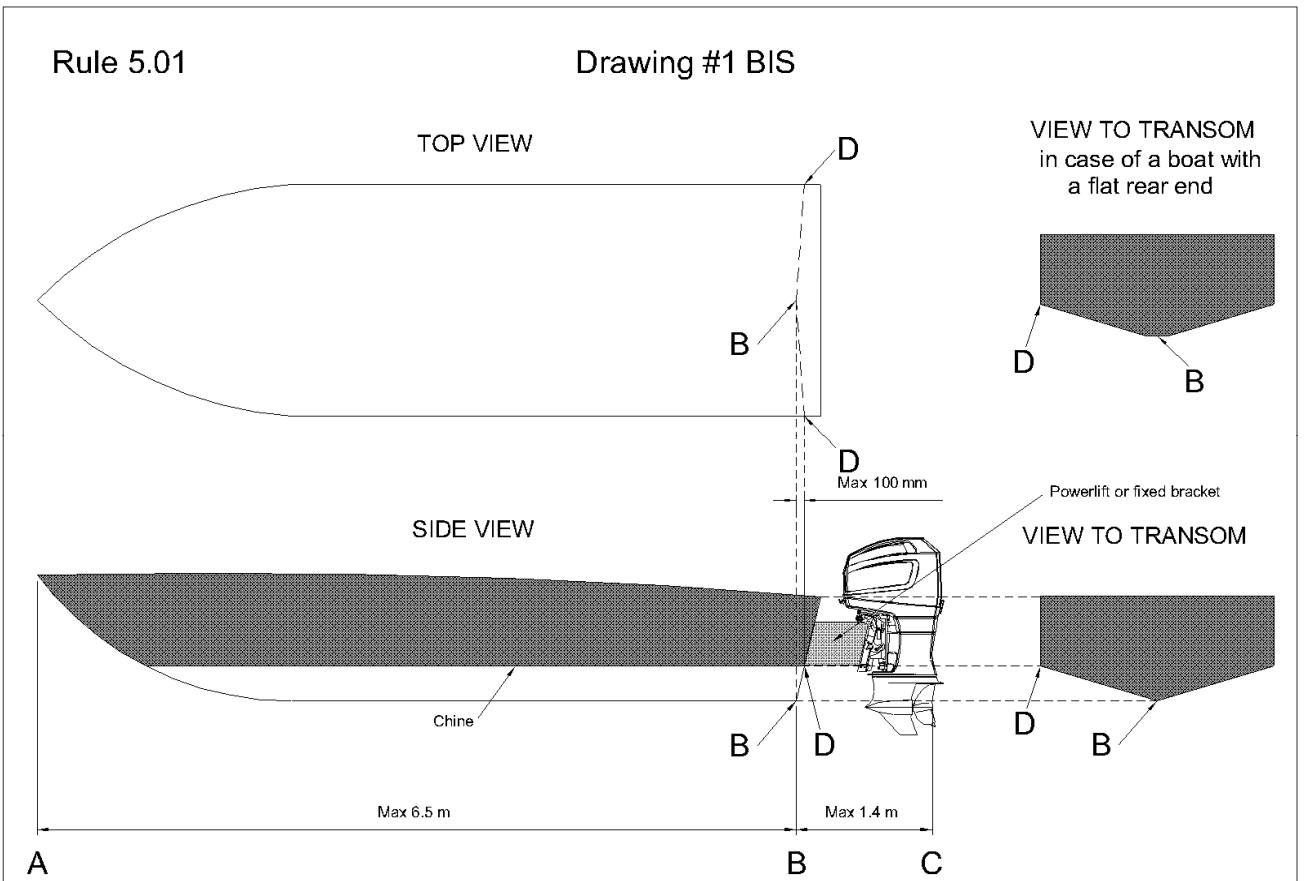
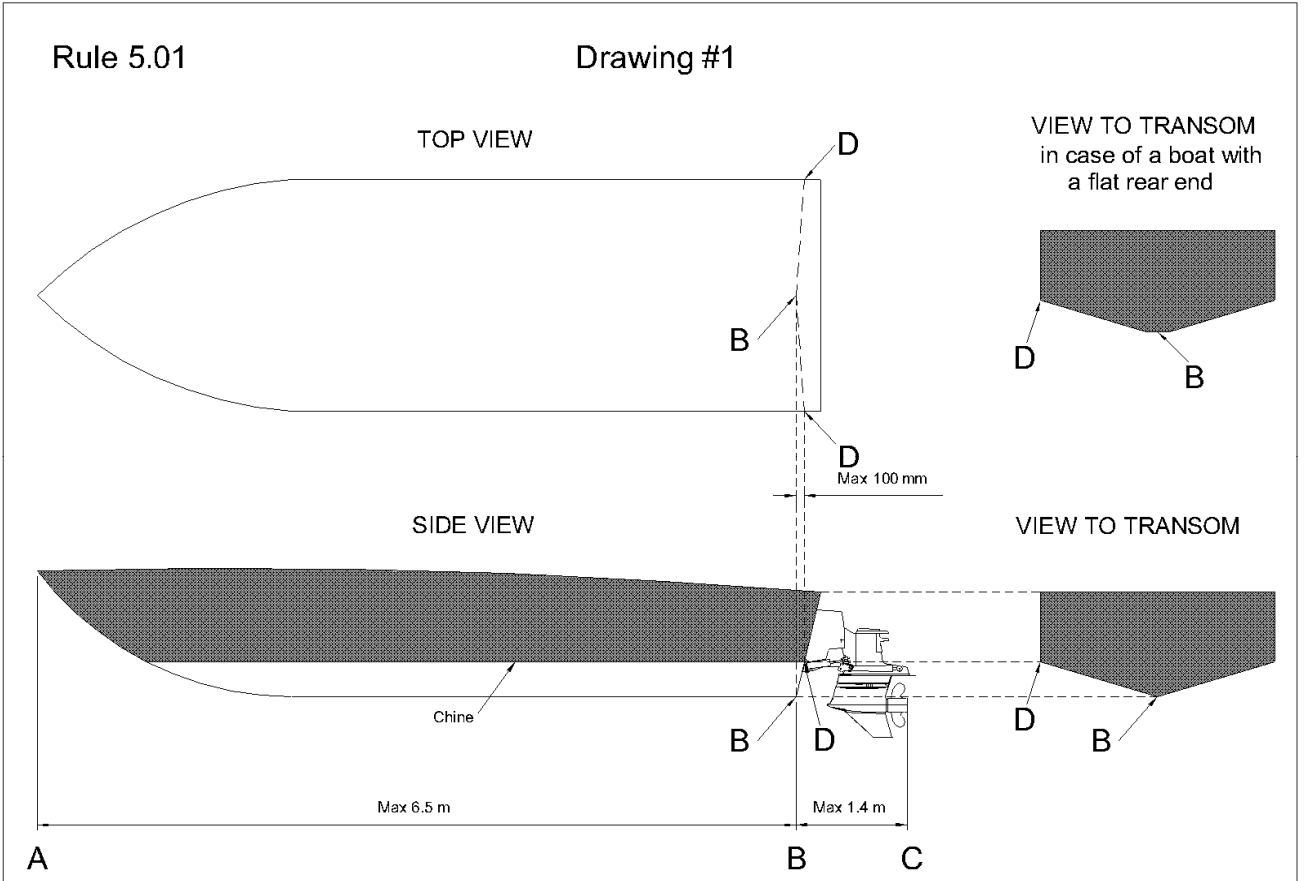

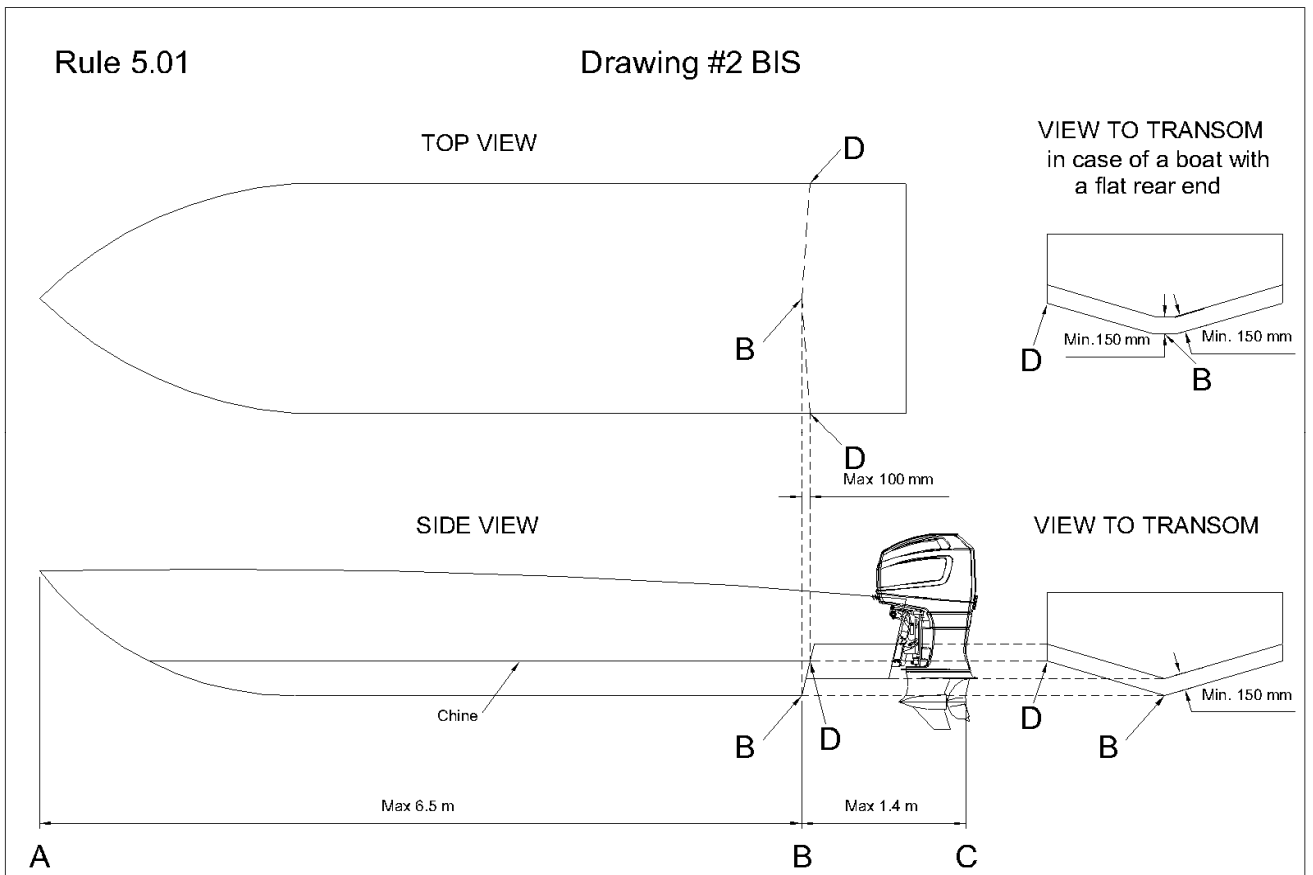
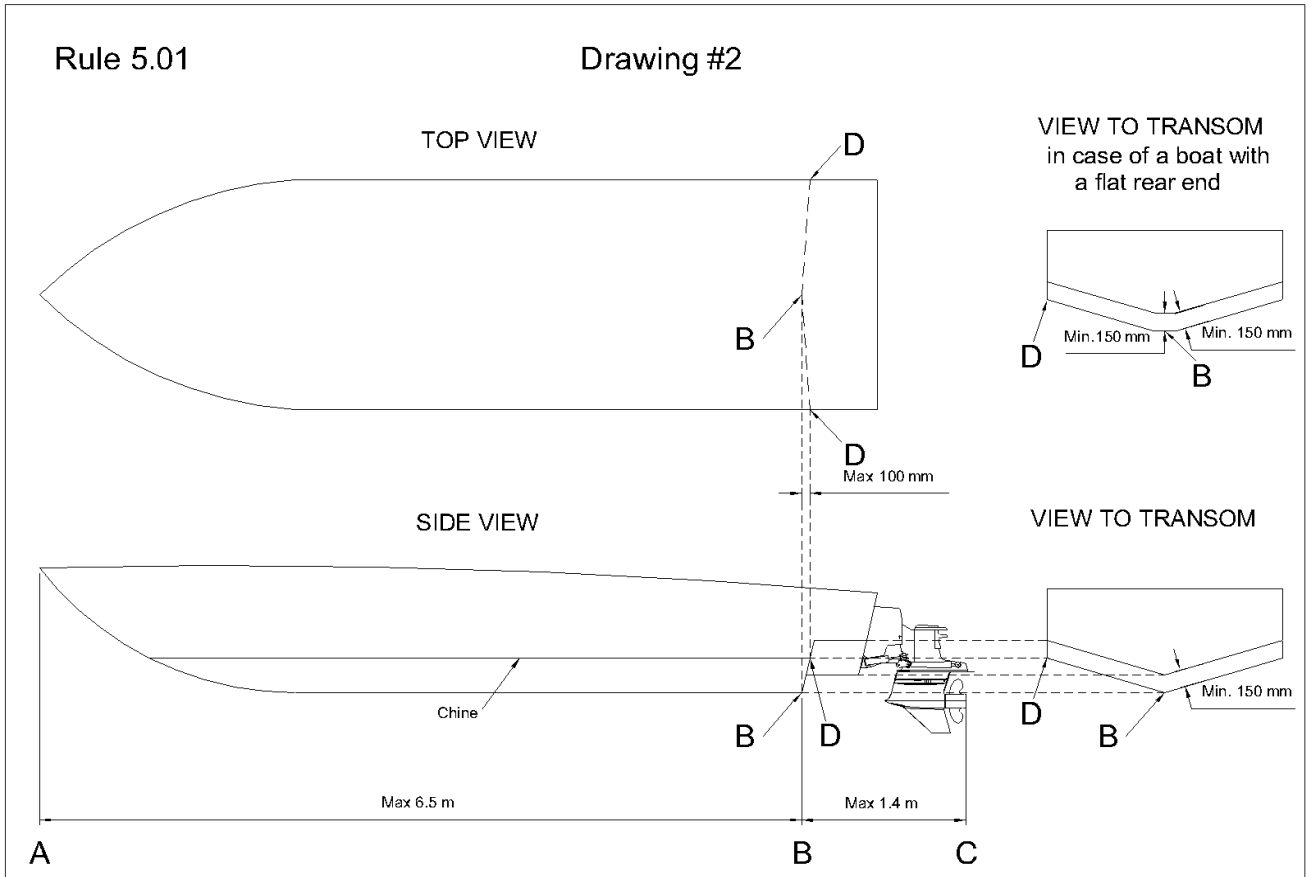

5.02 Total displacement of the engine(s) whether inboard or outboard shall not exceed 9.42 litres or 575 ci. Formula 2 as per Rule 5.34 [PENALTY 12.01 -- Disqualification](#)

5.03 Numbers must be displayed in black on a background of white, by means of waterproof material, in such a manner that they are visible on both sides of the boat when planing. On a white or light coloured boat a thin framed edge must be placed around the background a minimum of 25mm from the number edge. **The numbers should be block figures** to the following minimum dimensions of individual numbers -- Height 300mm, Width 225mm, Thickness 50mm and Spacing 125mm. However, if hull space permits, larger numbers are encouraged. **It is at your own risk to use serifs, shadows or Italic/Slanting numbers. Numbers must be clearly visible from a distance of a minimum of 200m.** The number can only consist of maximum 3 figures and no boat will be allowed to start in a race until the requirements of this Rule are satisfied. *Numbers will be attributed by each Federation in accordance with the numbers allocated to them by E&A Racing Council.*

[PENALTY: 12.02: 3 % & Numbers to be corrected by next race – failure to do so will result in 6 % and ultimate Disqualification](#)

5.04 Towing Cleat or Eye
Shall be adequate in itself and shall be adequate for towing the boat when water logged.

5.05 Tow Rope/Mooring Lines

- a) Shall be strong enough for the purpose.
- b) The tow rope shall be **permanently** attached to a bow eye and shall be secured in the cockpit, preferably by jamming cleat to avoid the crew having to clamber out on to the bow to accept a tow.
- c) It shall not be long enough to reach the propeller.

[PENALTY 12.02 FIXED: 1%](#)

5.06 Sharp Edges

All mascots, lights, bow fittings and other sharp edges shall be adequately protected or removed.

5.07 Windshield (if fitted)

- a) Shall be well secured.
- b) Shall not be of plate or ordinary glass.
- c) Scrutineers may order the removal of any windshield that appears dangerous.

**5.08 Steering Gear: Cable, Hydraulic, Dual-Ride steering is acceptable.
No wireless steering allowed**

- a) Steering wheel and drum shall be secured and locked on to the shaft.
- b) Steering wheel unit shall be fixed to, or through, the dash panel or a steering mounting bar and shall be through bolted and locked.
- c) Steering wheel strength shall be checked, if the wheel is split or cracked the wheel shall be rejected. Wheels of the laminated rim type shall be checked for wear caused by the breakdown of the laminations. Plastic composition wheels shall be checked for early fatigue where the spokes join the boss to ensure the wheel cannot be forced to spin on the internal boss without undue minimum amount of pressure.

- d) Where shackles or such devices are used to attach the steering to outboard engines, they shall not be of a non-ferrous metal. Scrutineers shall satisfy themselves this is so even if the shackles are painted.
- e) For outboards - attachments to the engine, for inboards attachments to tillers and/or quadrants and their fitting to the stock shall be in good condition and secure.
- f) Engine or tiller and rudder shall operate with full and free movements in the correct sense.
- g) Rudder assemblies, gland keys etc shall be in good condition and secure with locked nuts and/or tight split pins.
- h) Rack and pinion steering shall be in good mechanical condition with no excessive backlash. Casings should also be checked.
- i) Jet boats must be fitted with a rudder extending below the bottom of the boat and operating in conjunction with the normal jet steering.
- j) Inboards and Outboards - Repairs to Stern Drives
Should any part of the outboard/out drives be welded or repaired below the cavitations' plate line, then a certified x-ray to show structural integrity is required and must be permanently stamped or engraved on the cavitations' housing by the repairer with the date of repair for identification purposes. This certification must be renewed every 12 months.

Cable Steering

- k) Pulleys shall operate freely and shall be through bolted with positive locking.
- l) Steering wires shall be in good condition and shall have free running throughout their path, with adequate tension throughout their travel.
- m) Wires shall be secure and where doubled to form an eye shall be around a thimble and shall be secured with two bull-dog clips or equivalent.
- n) Lock wiring on all shackles, stretching screws etc, in the system shall be secure.
- o) There shall be no undue degree of play in the steering system, but steering wires shall not be over-tightened in a 'piano-wire' fashion.
- p) All pulleys with riveted pins of non-ferrous materials shall be rejected or the pins shall be replaced by a positively locked steel bolt. Pulleys should also, if possible, incorporate a bush.
- q) All pulleys with any tension shall not cause the yoke to clamp down on the pulley sheer.
- r) All pulleys which use an attachment hook of non-ferrous material shall be rejected.
- s) All attachment hooks shall be closed.
- t) Sheathed steering cables shall not be permitted, morse type systems exempt.
- u) Wires to the steering steel running across the front of the dashboard shall effectively be shielded.
- v) It is also recommended wires running fore and aft inside the cockpit be similarly shielded.

Hydraulic Steering

- w) All hydraulic hoses shall be for hydraulic purpose only.
- x) There shall be no leaks in the hydraulic system
- y) All bolts that connect the hydraulic pumps to the boat and motor shall be secured.
- z) Oil filters and oil coolers shall be firmly attached to the boat or motor (for inboards).

5.09 Control Cables

All control cables shall be taped or screwed down securely.

5.10 Fuel Tanks

- a) Shall be secure in all directions.
- b) Shall not leak.
- c) Shall have sensible filling and venting arrangements where applicable, that are not close to any hot parts, such as exhaust manifolds.
- d) Should be insulated or isolated from the engines etc, preferably by bulkheads.
- e) It is recommended there should be an easily accessible means of shutting the fuel supply off from the tanks.

5.11 Fuel Lines and Fuel Type

- a) Shall be lead resistant and run in a manner to avoid damage. Lines shall be in good condition with proper connectors. Flexible hoses and pipe runs should be clipped up at suitable intervals with fair runs to the engine (at all points of travel in the case of outboards).
- b) Fuel or gasoline is unrestricted and competitors are responsible for the supply of their own type of fuel.
- c) The delivery, transportation, and storage of the gasoline used, shall comply with the law and regulation of the host country. This concerns also the environmental regulation which shall be fully respected.

[PENALTY 12.01: Disqualification](#)

5.12 Jack Plug and Throttle Control

- a) Path and length of the cord shall ensure disconnection of the plug whatever direction of ejection.
- b) Plug cord and attachments shall be adequate, a spare plug to be carried in the boat.
- c) Shall actually cut the engine completely when operated.
- d) No device shall be fitted to render the jack plug inoperative.
- e) Control unit shall be within easy reach of the driver in his normal position.
- f) Unit shall be attached securely to the boat structure.
- g) All throttles must be operated by foot whether inboard or outboard. Throttles must be spring loaded to close at the engine and must function accordingly.

[PENALTY 12.01: Disqualification](#)

5.13 Seats:

Seats shall be of adequate strength and firmly secured.

5.13(a) Handholds (minimum one):

All boats must have at least one fixed handhold in a convenient location for the use of the observer. They shall be located to prevent entrapment of boat crew.

5.13(b) Footrests (minimum one):

All boats must have an adequate footrest for the observer to be suitably located for bracing the observer within seat. They shall be firmly fixed and of such construction that the observer's foot may not be caught underneath.

5.14 Engine Mountings and Transmissions for Outboards

- a) Engine brackets shall be secure and in satisfactory condition.
- b) **Engine mountings shall be attached to the transom with at least four bolts with double nuts or self blocking nuts.**
- c) All bolts shall be adequately tightened.

- d) To restrict the height a single outboard is mounted on the transom with the outboard trimmed so the prop shaft is parallel to the bottom of the hull, the centre of the prop shaft will be no higher than the bottom of the hull (plank or vee). No removal of metal from the skeg and no modification to the water intake.

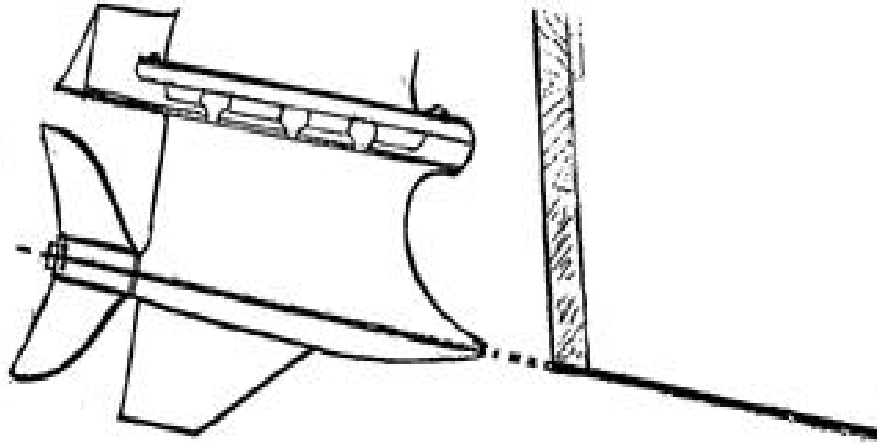

For Inboards

- e) Engine mountings shall be sound, and the mounting bolts securing to the hull shall be pinned or lock-nutted.
- f) Where an outdrive (or jet unit) is fitted, the outdrive ring connection to the transom and the unit to the ring shall be secure.
- g) Transmission and all parts motivated by the engine shall be efficiently shielded so as to prevent damage to persons or structure in the event of breakage. For shafts in excess of one foot in length the shielding shall not allow more than 1cm clearance at either end.
- h) Bearers shall not be saturated with oil.

5.15 Engine Condition

- a) The engine shall be free of dangerous corrosion, oil or fuel leaks or excessive heating and shall not be a danger to any adjacent structure. Oil leaks are a particular source of fire danger.
- b) For inboard engines, flame traps are recommended.

5.16 Electrical Harness

Properly protected terminal boards shall be used with flexible (not solid core) cabling supported well up to the terminals and at suitable intervals throughout their runs. Where relative movement or vibration occurs across a gap, cable shall be sheathed in plastic or metal tube anchored at both ends. Reinforced cable suitable for marine duty should be used. Electrical equipment in engine compartment shall be a minimum and away from heat or fuel.

5.17 Exhaust Systems

Shall conform to organising Federation's standards of decibels or a maximum of 105 db(A) at a distance of 30 metres. There shall be adequate insulation where required and runs sited to avoid fire.

PENALTY 12.01: Disqualification

5.18 Propeller Security

- a) Propeller shall be sound, particularly at the blade roots.
- b) It should be ascertained that the propeller nut can be securely locked.

5.19 Battery Stowage

- a) Batteries, where carried, shall be easily accessible and prevented from any movement in any direction.
- b) Shock cords shall not be accepted for batteries in excess of 4.5kg weight. (Remember a 15kg battery weighs over 150g at 10g.) See there is adequate support below the battery.
- c) Batteries shall not be placed in a sealed compartment.

5.20 Engine Eligibility

Scrutineers shall check to ensure an engine specification has not been changed from that recorded before the race. Scrutineers are not expected to remember specifications of each and every engine; they should inspect for any fairly obvious sign that might have altered the declared engine displacement.

The Chief Judge in consultation with the Chief Scrutineers can request any pre or post race strip or examination of any engine or engines which they consider necessary for whatever reason (eg. bore/stroke, pistons, gearbox or Electronically which may have been altered in order to exceed manufacturers engine specifications), at competitor's expense.

If the Chief Judge receives a protest about an engine or engines from Team Captains he/she can call for any engine/engines to be tested at anytime at the Team Captain(s) expense. The protest must be received by the Chief Judge in the usual manner with a fee of 50€ plus the real cost of the engine test of which they will be notified.

If the engine/s is found to be illegal the cost of testing will be borne by the offending owner. The engine and boat will be banned and not be allowed to take part in any race until rechecked. Engine owner to pay for the re-test.

If the engine/s are found to be legal the 50€ protest fee plus the test money will be lost.

Engine Height

The height of the prop shaft in relation to the bottom of the boat must be either level or below the bottom of the boat (this measurement is taken when the motor is at level trim). Hydraulic jacking plates & engine height must be static therefore not adjustable while in motion.

All Electronic Control Units will be production units applicable to the model and serial no of the unit.

[PENALTY 12.01: Disqualification from Individual Race or Championship](#)

5.21 Structural state:

Scrutineers are not expected to undertake a "condition survey" of the boat, but a general appraisal shall be made of the structure. The following points should be checked however:

- a. Split planks, fractured frames and beams and transom knees or their equivalent in reinforced plastic of alloy hulls.
- b. Steering mounting (structure).
- c. Shaft brackets and mechanical items other than those already covered.
- d. Bilge shall be free of oil or debris. Remember oil causes structural deterioration, fuel is dangerous and debris chokes pumps etc.

- 5.22 Anchor** (if required by the organisation)
Shall be of weight and type adequate to hold the boat. Shall be properly stowed to prevent damage, but shall still be accessible. The use of an anchor shall be governed by the type of venue or if a requirement of the local marine authority.
- 5.23 Anchor Line**
If anchor required, the following shall apply for anchor line:
a) Shall be of a size and strength appropriate to the boat.
b) Shall be in good condition.
c) Shall be at least 35 metres in length.
d) Shall be attached at the time of scrutineering, to the boat and the anchor. It shall perform no other function.
- 5.24 Extinguisher System**
a) Shall be of satisfactory condition and easily accessible.
b) Only fully charged extinguishers shall be permitted and they shall not contain carbon tetrachloride. It is recommended the extinguisher be capable of putting out a petrol fire of at least 4 sq metres
- 5.25 Buoyancy.**
All boats shall have sufficient buoyancy to keep afloat in all conditions.
Buoyancy aids or material shall be adequately fixed. Scrutineers shall not be responsible for determining the adequacy of the buoyancy in any boat, but may suspend clearance if in doubt and refer the matter immediately to the Chief Judge.
- 5.26 Compasses** (if required by the organisation)
a) Main compass shall be securely mounted and should be able to be read by pilot.
b) There shall be no metal or magnetic objects in the vicinity of the compass.
- 5.27 Boat number on trailer**
To assist recovery boat numbers should be painted clearly on the trailer on the starboard side at the hitch.
- 5.28 Flares** (if required by the organisation) Smoke signals are recommended for daylight use and flares after dusk. Flares normally have a stamped expiry date and if they have expired or the date is illegible or the condition poor, they shall not be accepted. A minimum of three flares must be carried.
- 5.29 Bilge Pump**
a) Shall be in proper working order and properly secured to the boat.
b) Shall be reasonably accessible for operation.
c) Shall have a suction pipe to the lowest suction point of the bilges and a discharge pipe overboard.
d) It must be possible to pump out all sections of the boat, even if separated by water-tight bulkheads.
- 5.30 Engine Wells.**
For boats with engine wells, any non-sealed openings, other than self-draining holes in the transom, shall be above a horizontal line through the lowest point of the top of the transom.
- 5.31 Flag Pole Holder**
To be fixed to the boat in an accessible position for the observer to put up the orange flag, or any other flag, whilst still sitting in their seat.

5.32 Paddles (Minimum one)

- a) Shall be stowed for immediate use, not loosely stowed.
- b) Shall be of practical form related to the size of boat and in useable condition.

5.33 The Chief Judge shall have final authority to determine whether equipment to be used by a contestant meets the above safety requirements.

5.34 Formula II Rules.

- a) Hulls – Minimum length of hull shall be 18 ft or 5.48 metres. See Rule 5.01.
- b) This class is for single outboards, single propellers
- c) Standard low emission as per EPA or CARB or EU2006 regulations and onwards only. No modifications are permitted with the exception of nose cones and torque tamers. The manufacturer's original location for water pick ups must be maintained. No performance enhancing.
- d) Engine capacity – Maximum manufacturers rating of 300HP as per **ICOMIA** Rating schedule 28 (**International Council of Marine Industry Associations**).
- e) All engines must carry original manufacturer's model number, serial ID plates, stickers or tags. These will be located on the engine.
- f) The upgrading of engines from their original year specifications will not be accepted.
- g) The factory supersession of parts is acceptable.
- h) Standard gear box available for the engine model only.
- i) Must run standard manufacturer's exhaust system.
- j) All engines must have operational forward, neutral and reverse gears controlled from the cockpit.
- k) Steering - cable, hydraulic or dual ride guide steering is acceptable but must meet the requirements of steering rule 5.06.
- l) No mechanical means of height adjustment for the motor whilst in motion.
- m) Original factory Engine Management System to remain in place and unaltered.
- n) No steering or throttle is to be wireless.
- o) F-2 class shall be restricted to commercially available unleaded pump fuel. No avgas, racing fuel or octane boosters.
- p) All engines will be inspected and sealed by the organizing committee prior to the competition.
- q) All engines competing in F2 will be technically inspected after each race and at the completion of the competition.

Definition of a Standard Motor for FII & Procedures for Checking

Motors must be a stock production out of the box unit with no additional porting, polishing,

blue printing, de-burring and no removal of any metal will be allowed.

Re-sleeving or re-boring will be permitted up to a maximum of 3 cylinders, but will not be permitted as an aid to enhance performance. Replacement parts etc to be those catalogued as such by respective outboard manufacturers for the applicable engine.

Exceptions are spark plugs, propellers, carburettor jets, timing, fitting nose cones, torque tamers, fibreglass / plastic reeds (no double "piggyback" reeds allowed unless fitted by the manufacture as part of the standard engine). *As a safety measure it is not compulsory to have oil injection operational, but its removal as a weight saving exercise is not allowable.* No louvered cowls other than what has been installed by the manufactures as part of a standard outboard. *Removal of the fuel connection bayonet is permissible.*

Electric fuel pumps are acceptable provided fuel passes through original, unaltered fuel pump on engine and is operational.

All outboards must have operational forward, neutral and reverse gears.

Nose cones are not to have additional fluting to aid water pick-up, other than the original contour of the gear box no water pick up to be blanked off.

Changing of engines from their original years specifications to another year's specifications will not be allowed.

The upgrading of engine H.P. is not allowable.

All engines must carry original manufacturer's model number and serial number plates or tags. These tags must be attached to the engine.

5.35 Formula III Rules:

Engines: 150 HP Maximum Horsepower – about 111,85Kw. (with 5% tolerance) at the propeller shaft. Only motors, standard out of the box, sold by the manufacturer as max 150 HP are allowed.

The Formula III boats, must comply with all the specifications as per Rule 5, from point 5.01 to 5.35, as shown in the current EA Racing Rule Book, with only the following modifications allowed:

- a) Minimum Length of the hull 18ft or 5.48 metres.
- b) This class is for Single outboards only.
- c) Seating Pilot and Observer side-by-side. Backward facing Observer seat can be positioned aft of drivers seat.
- d) Standard Recreational outboard engines of 2 stroke, direct injection, or 4 stroke. Not racing or high performance.
- e) Maximum power of 150 HP/111,85Kw, measured at the propeller shaft as per ICOMIA specifications.
- f) Standard Manufacturer's Exhaust, under water level
- g) Only allowed to change the propeller pitch
- h) Steering. Dual Cable or reliable Hydraulic Steering System
- i) Ballast tank allowed
- j) Bracket, if fitted, adjustable only by hand, not during navigation
- k) Boat construction: Normal materials like on the recreational boats. Not permitted other materials used for racing like carbon fiber, etc.
- l) All engines must have operational forward, neutral and reverse gears.

Older engines which produce 150hp maximum horsepower are still allowed to race.

RULE 6: CREW OF THE BOATS & COMPETITORS EQUIPMENT

- 6.01** The crew consists of a boat pilot and an observer.
- 6.02** The minimum age for a driver shall be 18 years of age and the minimum age for an observer shall be 18 years of age.
- 6.03** Either one or two skis may be used. But skis must be:
- In serviceable condition.
 - The skis must be fluorescent flame orange except fins and bindings and running surfaces. The underside of the ski from the tip must be orange for at least 20cm. **PENALTY 12.02 FIXED: 6%**
 - Competitors may tape lower legs, feet or ankles, but not in a manner that would stop their feet coming free of the ski binders in the case of a fall. Legs, ankles or feet must not be taped directly to either the ski or binders. Any type of harness to stop free movement of legs, ankles or feet is prohibited.
- 6.04** The minimum length of the tow line is 21 metres, including handles, with a maximum length of 75 metres also including handles. Length of ski tow line to be limited and governed by safety and venue. Races on Canals, Rivers and circuits with tight corners the ski rope length, including handle **will be a maximum length of 60 metres** for FI, FII, FIII, Men, Ladies **Juniors** and Seniors and 50 metres maximum including handles for Euro-Kids. Allowing a 5 % discretion after measurements. **PENALTY 12.02 Fixed: 6%**
- 6.05** Either single or double handles may be used, ski ropes and handles to be part of skier's personal equipment.
- 6.06** Life Jackets & Buoyancy Vests - Skier
- A buoyancy jacket of the ski jump type easily visible and predominantly a fluorescent colour - excluding white, black or silver.
 - A wet suit or buoyancy belt is not adequate.
 - Leg or hold down straps are mandatory.
 - Wet suits designed for ski racing with built-in buoyancy will be accepted only if they are of a fluorescent colour.
- NOTE:** i) Wet suits must conform to colour.
ii) Leg straps are not necessary on buoyancy vests if under wet suit. **PENALTY 12.02 Fixed: 6%**
- 6.07** Life Jackets, Buoyancy Vests & Footwear – Pilot and Observers shall wear a life jacket in an easily visible and conspicuous - excluding white, black or silver. All boat crew members competing in events shall be required to wear a waist-coat type unaltered life jacket with leg straps.
Life jackets must be equipped with collars and/or must have flotation material high on the chest to hold an unconscious person's face out of water. Life jackets and life collar, if any, must be securely fastened at all times, while on course - racing or testing. Leg straps must be securely fastened to life jacket and legs. Life jackets must meet the following inspection requirements:
- Lacing ties and/or straps shall be adequate and in good condition.
 - Zips, where used, shall be in working order.
 - Tears or rents or bad repairs whereby buoyancy will leak out shall not be permitted.
 - Jackets shall be dry and not oil or water-logged.
 - Jackets shall be fitted with hold-down straps to the legs.
 - Closed toe footwear is compulsory. **PENALTY 12.02 Fixed: 6%**

6.08 Crash Helmets

SKIERS shall wear helmets which are fit for purpose and meet the following requirements. Checked for individual fit by Scrutineer.

- (1) The colour fluorescent flame orange.
- (2) Cover for the ears to prevent ruptured ear drums when the head hits the water in a sideways fall.
- (3) A secure fit on the head.
- (4) Secure straps.
- (5) The helmet must float.
- (6) The possibility of 'bucketing' or forcing water between the helmet and the head to be reduced by either a very close fitting about the head or substantial drain holes fitted within the helmet.
- (7) Full face helmets are not allowed.

PILOTS and **OBSERVERS** shall wear helmets in good condition and conforming to International Safety standards. The colour must be fluorescent flame orange, devoid of dents and splits. Any holes drilled to improve hearing must not exceed 4mm diameter nor number more than one each side. (This is in order the helmet is not weakened.) Helmets' visors shall be in good condition and devoid of cracks and easily detachable (i.e. not bolted down). Visors must not be secured in any way which prevents them lifting up (i.e. taping). [**PENALTY 12.02 Fixed: 6%**](#)

6.09 Orange Flag

Observers shall have available in the boat a flame orange flag not less than 50cm x 50cm fixed to a pole of minimum 1 metre length for use when skier is in the water. Flag must be clean and free from grease.

6.10 Blue & White Medical Flag

All boats will carry a blue and white medical flag, dimensions 50cm x 50cm. The flag will be ½ blue and ½ white split diagonally (blue on the top, point of diagonal to be nearest pole) attached to a minimum 1 metre pole. To be used to summon urgent medical attention. Flag must be clean and free from grease.

RULE 7: FLAGS

7.01 The following flags are required:

- National** The National flag may be used as a starting flag. Dimensions: 100cm x 100cm
- Green** Pre start and identifying flag for Judges, safety and rescue boats. Dimensions: 100cm x 100cm
- Yellow** Caution. The Judges and Safety boats will raise the yellow flag when a skier has fallen, when a skier is in the water or in any other case of interference after the National flag has started the race. Dimensions: 100cm x 100cm
- Red** Stop the race. The Judges and Safety boats will raise the flag to stop the race. At the completion of a race the raising of the red flag will indicate "return to the pit area". Dimensions: 100cm x 100cm
- Black** Disqualification. The black flag is used to notify a competitor he has been disqualified and must retire from the race. Whenever possible when the black flag is shown the number of the team being disqualified should be displayed in figures not less than 300mm high at a point designated by the Chief Judge. Dimensions: 100cm x 100cm
- Blue** The blue flag is used to signal to all competitors that the leader of the race has begun his last lap. Dimensions: 100cm x 100cm
- Chequered** Finish: **The chequered flag indicates the end of the race. Dimensions: 100cm x 100cm**
- Blue and White Medical Flag:** All boats will carry a blue and white medical flag. Dimensions 50cm x 50cm. The flag will be ½ blue and ½ white **(separated diagonally Point of Blue diagonal at top nearest the pole)** on each side. This flag will be raised only when Medical assistance is required.
- Orange** For use by Observers when their skier is in the water. 50cm x 50cm

7.02 Each Judge's boat must continuously fly a green flag for identification; they also carry yellow, red and black flags on board. The red and the black flags can only be used after communication with the Chief Judge, and on his/her instructions.

7.03 The Safety and Rescue boats must continuously fly a green flag for identification.

7.04 **Display Board**

It is recommended that a display board be mounted in full view of the spectators and the competitors, to display current positions of competitors

RULE 8: DEPARTURE & CIRCUIT

8.01 Details of the competition shall be given by the organisers with the help of an Event Dossier given to the team Captains for distribution. All courses shall run in an anti-clockwise direction. *There shall be a minimum water depth of 1.5 metres for all courses.*

Race Distances:

FI, FII Men	50 min + 1 lap
FI, FII Women	35 min + 1 lap
FIII Men and women	35 min + 1 lap
Seniors	35 min + 1 lap
Juniors	35 min + 1 lap
Euro-Kids B	25 min + 1 lap
Euro Kids A	15min + 1 lap.

Before a race may be declared a minimum time of 51% of the race must be recorded.

8.02 According to local circumstances any of the following methods of starts may be used:

- a) Grid start: Grids must be staggered with a minimum starting interval of 10 (ten) seconds between grids.
- b) Simultaneous mass start.

8.03 All starts are only allowed if a distance of at least 10 metres on either side of each competing boat is allowed for. It is recommended the distances between the starting line and the first turn is 2.5kms and races to be conducted over a 5km course where possible.

8.04 For simultaneous mass start, a 5 minute signal shall be given by raising the National flag together with a green flag on a starting boat or dock in sight of the skiers and boat crew. The 30 seconds signal shall be given by lowering the green flag. Skiers may then enter the water from their boats which may take up the slack in the ski line. The start will be signalled by the lowering of the National flag and skiers must not be in a skiing position until the start is signalled.

- a) When the starting procedure is stopped the red flag must be raised during the interruption. The new start procedure shall be of 3 minutes instead of 5 minutes. The new 3 minute start shall follow the normal procedure.
- b) In grid starts the boats must start from the position they are allocated.
PENALTY 12.02 Fixed: 1%
- c) Boats must remain in their starting positions, without moving, unless exceptional weather conditions exist.
- d) When grid starts are being used and a skier misses his/her pull the towing boat is **NOT** allowed to turn to pick up the skier until all grids have passed. The observer should pull in the ski line out of the way of other boats before going to their skier.
PENALTY 12.02 Fixed: 9%
- e) Boats **MUST** not be over start line prior to the lowering of the National flag (Startline to be defined at Team Captains Briefing).
PENALTY 12.02 Fixed: 1%

8.05 It is obligatory that all turns shall be marked by buoys, moored vessels or permanent sea marks. All course markers shall be passed on the outside. No passing on the inside or changing of lanes is permitted from within 100 metres of the turn buoy or mark, this distance to be clearly shown by a 100 metre buoy or marker, until the skier rounds the buoy and attains a straight line on the natural course.

PENALTY 12.02 Fixed: 1 LAP LESS
In case of repetition Fixed: 3 %

- a) If the course turns are considered tight such as on a Canal a Box System (an imaginary line drawn across the Canal dissecting the 100m buoy and an imaginary line drawn across the Canal at 50m past the Turn Buoy) should be used. All skiers falling in this area must be picked up and taken to the SAFEST POSITION outside of the box. The ski line must be retrieved before picking up the skier).

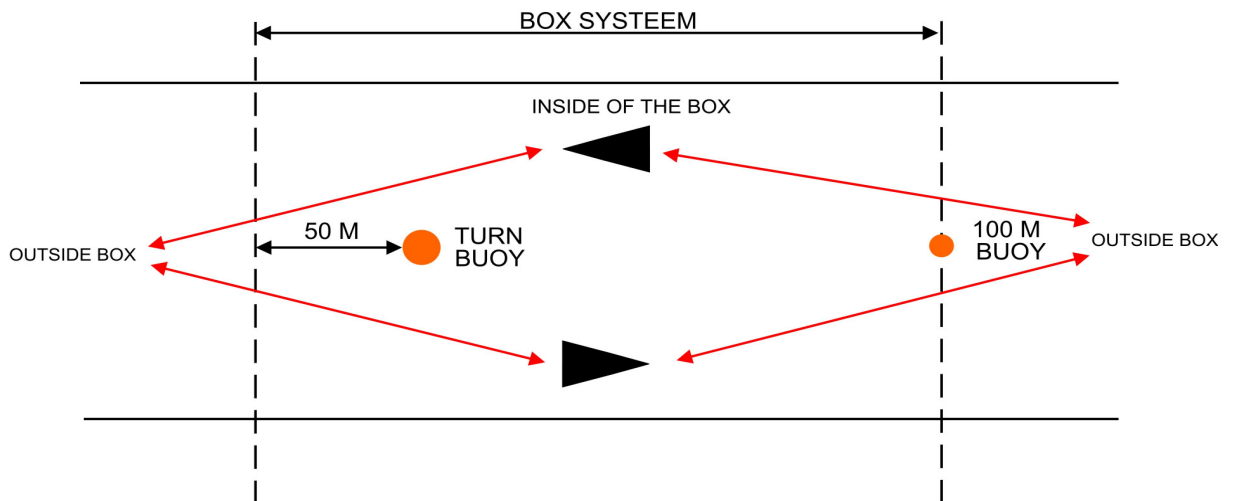

PENALTY 12.01 Fixed: 6 %
in case of repetition: DISQUALIFICATION

- 8.06** Boats, which can take aboard at least two Judges chosen by the Chief Judge, will stand at near proximity to all turns.
- 8.07** In closed circuit racing the Jury must state at the briefing and display on a blackboard the manner of passing other competitors. The designated manner of passing other competitors must be complied with. A fallen skier may be passed on whichever side is deemed to be the safest. (Also see rule 9.01) **PENALTY 12.02 Fixed: 6%**
- 8.08** The passing pilot / observer shall acknowledge sight of a fallen skier by raising a hand. Failure to comply will incur a penalty. **PENALTY 12.02 Fixed: 1%**
- 8.09** A skier or a team shall not be allowed to start or continue in the competition if, in the opinion of the Chief Judge, after consultation with the Safety Officer and/or Jury, their presence would be a danger to themselves or other competitors.
- 8.10** The organisers must provide an adequate rescue service at all times during the competition.
- 8.11 Substitution of Boats:**
A competitor may substitute a boat or engine once a boat or engine is pronounced unserviceable by the Chief Scrutineer, advising the Chief Judge who will rule. The Chief Judge may obtain independent technical advice.
The original hull or engine may only be resubmitted with the specified permission of the Chief Judge.
- 8.12** IWWF rule – not required for E&A

8.13 Grid Positions: For first race Federation's nominees by means of a Draw, after first event grid positions will be allocated on each competitor's accumulated performance.

For 2012:

Start Grid placing at E&A Events— for the first race Federation's nominees by means of a draw, after first event the winner of each round will take pole at next race, so no longer based on accumulated points.

8.14 In the event of a race having to be red flagged, if the race is 51% complete, then the event is final. If the race is less than 51% complete the race will be started again. Following a red flag situation the Chief Judge will decide whether the race will be a continued race or an entire new race.

If the restart is a continuation of the original race, the number of completed laps prior to the red flag is carried forward to the restarted race and the pole positions will be determined by the placing as of the last completed lap prior to the red flag. The team causing the red flag, and teams who have retired from the race, are not allowed to restart the race whether the restart is a continuation of the original race or a new race
Procedure to be followed when a red flag is displayed to stop a race.

1. *All Judges are to display a red flag.*
2. *All competitors must stop immediately that it is safe to do so and remain where they are for instructions.*
3. *No further laps will be timed after the red flag is shown.*
4. *When red flag is lowered, or instructed to do so by a Judge competitors may return to the recovery area.*

[PENALTY 12.01 Fixed: Disqualification](#)

RULE 9: CONDUCT OF RACE

- 9.01** In case of a fall of a competitor, the pilot must immediately stop the boat and the observer must display the flame orange flag and immediately retrieve the ski line. The pilot will turn to pick up the skier without interfering with the progress of the race. In picking up a fallen skier the pilot must give right of way to oncoming boats and then turn in whichever direction is safer. For canals, rivers or in general when the space near the turning buoys is narrow the Box System as described in Rule 8.05 will operate. The Observer **MUST** retrieve the ski line before picking up the skier.
PENALTY 12.02 Fixed: 6%
- 9.02** A fallen skier is allowed to make physical contact with the boat and crew to enable the replacement of equipment. At all times whilst such action is being carried out, the motor of the tow boat “will be dead or in neutral, ie. Propeller not rotating”. The flame orange flag must remain visible until the skier is in proper skiing position.
PENALTY 12.02 Fixed: 6%
- 9.03** For a single skier race the skier must remain in the wake of the towing boat for the entire race.
PENALTY 12.02 Fixed: 3%
- 9.04** An overtaking boat must not cut in until their skier is 100 metres ahead of the boat being overtaken.
PENALTY 12.02 Fixed: 6%
- 9.05** Observers must remain seated in the cockpit of the boat and must keep the skier under observation at all times during his participation in the event. **PENALTY 12.02 Fixed: 3%**
- 9.06** Boats shall not follow closer than 100 metres directly behind any skier except when overtaking, in which case it is imperative the driver should keep his boat in a different line than the preceding one. When a pass is completed, the skier who is at least 100 metres in front of the overtaken boat **may** move to the inside of the course.
PENALTY 12.02 Fixed: 6%
- 9.07** The pilot must keep his attention ahead of him at all times, and both hands on the steering wheel except when operating controls and when complying with rule 8.08
PENALTY 12.02 Fixed: 6%
- 9.08** Skiers are strictly prohibited from fastening their tow line or the handle of the tow line to their body in any way whatsoever. It is permissible to hook one arm through the bridle of the ski rope. No means of adjusting skier’s rope length allowed. Damaged ropes may be replaced during races.
PENALTY 12.01: Disqualification
- 9.09** The skier must always have at least one hand on his tow line.
PENALTY 12.01: Disqualification
- 9.10** **When taking a turn:** If the pursuing boat is behind the skier of the boat in front at the 100m buoy the pursuing boat does **NOT** have right of way into the corner and **MUST** not power up the inside or attempt an undertaking manoeuvre until the turn has been completed and a straight line has been achieved. When overtaking on the outside the outside team must leave room for the team(s) on the inside to turn and not attempt to cut the corner.
PENALTY 12.02 Fixed: 9%
- 9.11** Refusing to give way or obstructing other competitors is strictly prohibited.
PENALTY 12.02 Fixed: 9%

- 9.12** Drivers must maintain a minimum lateral distance of 2 metres between their boat and other competing boats after the start. [**PENALTY 12.02 Fixed: 5%**](#)
- 9.13** All team members shall wear their helmets and safety gear in the normally accepted manner during the race and whilst under power on race day and also during practice periods. [**PENALTY 12.01: Disqualification**](#)
- 9.14** Skiers must drop off in the areas and in the manner indicated by the Chief Judge at the pre-race briefing. [**PENALTY 12.02 Fixed: 3%**](#)
- 9.15** At no time during or after the event will any competitor or Team Official enter into unofficial discussions regarding decisions made during the event with any Judge.
- 9.16** On the day of the competition no alcohol to be consumed by competitors or officials until after completion of event. [**PENALTY 12.01: Disqualification**](#)
- 9.17** The use of drugs is prohibited as per the regulations of 1995 IWWF drug testing policy and procedure (legislation and WADA). [**PENALTY 12.01: Disqualification**](#)
- 9.18** Unsportsmanlike behaviour in the form of physical or verbal abuse will not be tolerated. It is expected that all competitors and officials will act in a civilized way towards each other. Contravention of this rule will result in a report being sent to E&A Racing Council by the Chief Judge for a decision on what action if any is to be taken
[**PENALTY 12.02: FIXED 6 %**](#)
[**In case of repetition: Disqualification**](#)
- 9.19** Random alcohol testing will take place, at a time determined by the Chief Judge, on race day off officials and competitors by the on site doctor. E&A operates a ZERO policy on alcohol. Failure or refusal to take the test will result in disqualification
[**PENALTY 12.01: Disqualification**](#)

RULE 10: TIMING

- 10.01** Timing will be accurate to at least one hundredth of a second, this precision holding good as well for departure as for arrival of a skier.
- 10.02** Places in the competition shall be determined according to the skier times made, after addition of the penalties, if any.
- 10.03** When the leading team completes 50min in the Men's FI, FII Race (35 minutes for FIII, Ladies, Seniors, Juniors) the blue flag will be displayed as the bow of the leading team's boat crosses the finish line to indicate the leader is on his/her final lap. The Chief Judge has the discretionary power to have the blue flag displayed to the leader, up to a maximum of 20 seconds prior to the designated time of the race. On completion of the leading team's final lap the black and white chequered flag will be raised and dropped as the lead skier crosses the line. All the following skiers will finish on the chequered flag, A maximum of 15 minutes after the leader crosses the line will be allowed for other competitors to finish the race.
- 10.04** A skier is not to be placed in a competition unless he is in a proper skiing position when crossing the finish line. A proper skiing position is defined as that position in which all of the following exists:
- a) The skier has possession of the tow lines.
 - b) The skier is riding forwards or backwards with a ski or skis on his feet.
 - c) The weight of the skier is entirely supported by his ski or skis and the skier is in good balance, or if he is able ultimately to regain a good balance.

10.05 1000 POINT RULE

In each complete race, points shall be awarded on the following basis:
The race shall be timed and the time of the winner will represent 1000 points, the remaining skiers will receive points based on the following formula:

$$\frac{\text{Winners Time from racing distance in average per 1 km}}{\text{Skiers/Team Time from racing distance in average per 1 km}} \times 1000$$

Such points to be calculated to two decimal places. The third place will be ignored.

A winner who normally gets 1000 points, shall not obtain the 1000 points, even if he remains the first in the classification, after being penalised.

In any case, for points calculations only the real time of the first skier will be taken. If the first skier is penalised, he/she shall not get a 1000 points, even if he is still the Winner of the Race, after penalisation.

The results issued after the races shall show the arrival times, average speed and points of skiers. The number of laps and the distance made shall be used only for the calculations.

RULE 11: PROTESTS

- 11.01** Protests regarding the results shall be made to the Chief Judge by the team representative in writing and filed within 15 minutes of the results being posted.
- 11.02** Protests directed against another contestant shall be made to the Chief Judge by the team representative. Protest must be in writing and indicate the reason for the protest. Protests must also give the names or identity of any other witnesses. They should be filed within 30 minutes after the arrival of the contestant or as defined by the Chief Judge.
- 11.03** **All** Protests must be accompanied by 50 Euros. This amount will be refunded if the protest is considered reasonable by the Judges.
- 11.04** Jury Panel decisions shall not be subject to team protests.
- 11.05** Team captains must accompany any individuals to any discussions regarding the protest.
- 11.06** Whilst a protest is being discussed or you have been called to the Chief Judge you must remain in close proximity to the meeting point.

RULE 12: EXCLUSIONS AND PENALTIES

- 12.01** For contravention of Rules 5.01, 5.02, 5.03, 5.11, 5.12, 5.17, 5.20, 8.05a, 8.14 sub 4, 9.08, 9.09, 9.13, 9.16, 9.17, 9.18 and 9.19 the penalty will be **disqualification**.
- 12.02** **Fixed Penalties Rules:** 5.03, 5.05, 6.03, 6.04, 6.06, 6.07, 6.08, 8.04 a/d/e, 8.05 + a, 8.07, 8.08, 9.01, 9.02, 9.03, 9.04, 9.05, 9.06, 9.07, 9.10, 9.11, 9.12, 9.14, 9.18 **a fixed penalty will be given**
- 12.03** For a serious contravention of the Rules the Chief Judge may, with a majority decision of the Jury, disqualify and/or recommend the **suspension or removal** of a driver's, observer's or skier's licence to the IWWF or E&A Racing Council Chairman. The re-issue of this licence, however, will be done through the offender's home Federation Technical Committee endorsed by the Region Racing Council on behalf of the IWSF, on re-application by the driver, observer or skier.
- 12.04** The Chief Judge and the Jury shall have the right to give **summary judgment** on any happening unforeseen in these Rules.
- 12.05** Repeat offenders should be dealt with under this rule. Action taken will be by the majority decision of the Jury. Decisions can be taken on the day or referred back to EAME if the offence is severe.

Ungentle manly conduct towards any official before during or after the event will result in the offender(s) having their results cancelled and their licences revoked.

For a serious contravention of the rules the Chief Judge can suspend the offender(s) from the competition.

EUROPE CUP WATERSKI RACING

RULES

- 1.00** The Europe Cup of Ski Racing will take place every year, following the International E&A Rules in power.
- 1.01** This Cup is open to Formula I, II, III Men and Ladies, Juniors, Seniors and Euro Kids A & B racing teams. There will be a separate classification for each division, concerning either the age or the Formula.
- 1.02** The Europe Cup will be run with a minimum of 3 (three) rounds and a maximum of 6 (six) rounds. There could be only one round each year in a country. In case of more than 6 rounds are proposed, the Racing Council will decide which one are to be kept, depending on the qualities of the sites and of the respective organizers.
- 2.00** At the end of the season the three first classified skiers of each division will be awarded of Region E&A medals: Gold, Silver and Bronze.
- 2.01** A classification will be done for each Europe Cup round on the basis of the 1000 points system.
The winner of the Cup will be determined by adding the points granted at each round with the following ready – reckoned:

<u>Nr. of Organized Rounds</u>	<u>Nr. Results to consider</u>
3	2 rounds included Final
4	3 rounds including Final
5	3 rounds included Final
6	4 rounds including Final

Competitors are reminded they must participate in the final round to be able to qualify for any medal position.

The skier with the highest total of points shall be declared “winner of the Europe Cup” for the year.

- 2.02** The results will be given after each round and the Region E&A medals award ceremony will take place at the Prize Giving Ceremony of the last round of the Europe Cup.
- 3.00** The fee to be paid at the Region E&A will be divided in equal parts among the organizing countries following the Region E&A list of obligations.
- 4.00** Concerning the Races, organized on the Cash Prize basis, the organizers will have to pay an extra fee to the Region E&A, in application of the Cash Prizes competition list of obligations to comply as well with the administrative obligations and with obligations concerning the Jury panel and the Officials

5.00 COMPETITIONS

The Europe Cups are open to the following categories:

- MEN:** Formula I, Formula II and Formula III
WOMEN: Formula I, Formula II and Formula III
(women are not allowed to race in Men’s race)
JUNIOR: Boys and Girls Open Formula The last year of eligibility of a skier is the year in which he/she has his/her 17th birthday.

SENIORS: More than 35 years of age on the 1st of January of the year of competition.

Men and Women will have distinct classifications.

Euro-Kids A; 8–9–10–11 years old on the 1st of January of the year of competition.

Euro-Kids B: 12-13-14 years old on the 1st of January of the year of competition.

Euro-Kids B skiers in their last year are allowed to enter the Junior Formula only, subject on approval from their Federation.

Skiers racing out of their natural age group need written permission from their parents and the approval of their Federation.

If a skier changes his/her category (Junior or Formula) it must be for the whole season with no possibility of reversion to the previous category.

It is possible for a Formula II to race as Formula I, and for Formula III to race as Formula II.

Categories will be run as follows:

- Euro Kids A - B
- Juniors and Men FIII
- Ladies F I/ FII/ FIII and Seniors
- Men FI and FII

If the time table at an event permits and numbers taking part justify Juniors/Men and Ladies/Seniors categories could be separated at the discretion of the organiser.

EUROPEAN CHAMPIONSHIPS

General

The European Racing Championships shall be held biennially in even numbered years subject to the current E&A rules.

The Championships will be a four race series with only the three best scores counting to individual overall standings.

All four scores will count towards team standings.

A classification will be made for each European Championship round on the basis of the 1000 points system.

The winners of the Championship categories will be determined by adding the points won in each round as outlined below in Competition Format.

The results will be given after each round and the Region E&A medals award ceremony will take place at the Prize Giving Ceremony of the last round of the Championship.

The Championship levy 2,700 Euro shall be paid to Region E&A by the host nation according to the Region E&A list of obligations.

CHAMPIONSHIP LICENCES for PILOTS and OBSERVERS

International Licences issued by the E&A Racing council are delivered by the National Federations to their teams, and shall be issued to the applicants, subject to the following instructions:

- Medical Certificate: Every licence holder must be in possession of a current Medical Certificate which must be updated every two years (see Racing Technical Bulletin and available on E&A website).

European Championship Format

The European Championships are open to the following categories:

- MEN:** Formula I, Formula II and Formula III
WOMEN: Formula I, Formula II and Formula III
(women are not allowed to race in Men's race)
JUNIOR: Boys and Girls Open Formula The last year of eligibility of a skier is the year in which he/she has his/her 17th birthday.
SENIORS: More than 35 years of age on the 1st of January of the year of competition.

Men and Women will have distinct classifications.

- Euro-Kids A;** 8–9–10–11 years old on the 1st of January of the year of competition.
Euro-Kids B: 12-13-14 years old on the 1st of January of the year of competition.

Euro-Kids B skiers in their last year are allowed to enter the Junior Formula only, subject on approval from their Federation.

Skiers racing out of their natural age group need written permission from their parents and the approval of their Federation.

If a skier changes his/her category (Junior or Formula) it must be for the whole season with no possibility of reversion to the previous category.

It is possible for a Formula II to race as Formula I, and for Formula III to race as Formula II.

Categories will be run as follows:

- Euro Kids A - B
- Juniors and Men FIII
- Ladies F I/ FII/ FIII and Seniors
- Men FI and FII

If the time table at an event permits and numbers taking part justify Juniors/Men and Ladies/Seniors categories could be separated at the discretion of the organiser.

Guest competitors (out of E&A Region): in case we have guest competitors on the podium an additional podium with separate trophies is mandatory

Team Trophy

The best 4 results per Country, counting on each race day, will receive these points for the team trophy excluding Euro Kids A or B

The Team Captain will nominate the grid position for the first round only at the first team captains briefing.

For further obligations and specifications look at the Technical Bulletin 2012 available on request from E&A Racing Secretary and published on the E&A Website.